

SOIL PHOSPHORUS FRACTIONS AS INFLUENCED BY DIFFERENT CROPPING SYSTEMS: I. DIRECT AND INDIRECT EFFECTS OF SOIL PROPERTIES ON DIFFERENT P POOLS OF NITISOLS OF WOLAYTA, ETHIOPIA

Research Article



Shiferaw Boke^{1*}, Sheleme Beyene², Heluf Gebrekidan³

¹Natural Resource Research Process, South Agricultural Research Institute, Hawassa, P.O Box 6, ETHIOPIA

²Department of Soil Science, Collage of Agriculture, Hawassa University, ETHIOPIA

³Department of Soil Science, Collage of Agriculture, Haromaya University, ETHIOPIA

*Email for Correspondence: abboshiferaw@gmail.com

Abstract

Data from 12 surface soils (0 – 15 cm depth) of three cropping systems (enset, maize and grazing land) and path analysis was used to evaluate effects of soil properties: pH, texture (Clay, silt and sand), organic carbon (OC) cation exchange capacity (CEC), citrate-dithionite-bicarbonate (CDB) extractable Fe and Al (Fed and Ald) on total phosphorous (Pt), organic phosphorous (Po), Olsen P (Available P) and Chang and Jackson (1957) inorganic phosphorous (Pi) fractions. Correlation analysis was performed to study the relationships between soil properties and different soil P pools while path analysis model was used to evaluate direct and indirect effect of these soil properties on the P pools. Only soil properties that significantly contribute to the fit of the model were used. High significant values of coefficient of determination (R²) and low values of uncorrelated residual (U) values indicate the path analysis model explains most of the variations in soil Pt, Po, Olsen-P, Saloid-P, Ca-P, Al-P and Fe-P pools. Soil pH had significantly high and positive direct effect (D = 0.618*) on Pt, (D = 1.044**) on saloid P, and (D = 1.109***) on Fe-P with modest and negative indirect effect (D = -0.478 and -0.405) on saloid P and Fe-P, respectively, through OC. The direct effect of clay on Ca-P, Al-P and Fe-P (readily available P forms) was significant and negative with relatively higher indirect effect on Fe-P through pH suggesting that clay is dominant soil property that influences readily available P pools in Nitisols of the study area. Fed had significant and negative direct effect (D = -0.430*) on Olsen available P with low negative indirect effect (D = -0.154) through pH results in significant and negative correlation (r = -0.657*). The significant and negative direct effect of Fed on Olsen P indicates that crystalline iron is the sink for available P. Relative influence of the soil properties on the soil P pools was in the order: pH > clay > Fed > OC. These results show that most of P pools of Nitisols of Wolayita is best predicted from pH, clay (texture), Fed and OC. On the other hand, our data also show that inclusion of other soil variables is needed to fully predict Ca-P and stable P pools (data not shown).

Key words

Soil properties, cropping system, P pools, Path analysis, Inorganic P fractions, Nitisols

10/30/2015

Source of Support: None, Conflict of Interest: None Declared

This article is licensed under a Creative Commons Attribution-NonCommercial 4.0 International License.

Attribution-NonCommercial (CC BY-NC) license lets others remix, tweak, and build upon work non-commercially, and although the new works must also acknowledge & be non-commercial.



INTRODUCTION

Phosphorus (P) is one of the essential nutrients for plant growth, and is of particular interest in highly weathered tropical and sub-tropical soils (Brady and Weil, 2002). Next to N, P has more widespread influence on both natural and agricultural environments than any other essential elements (Hedley *et al.*, 1995; Brady and Weil 2002). Several authors reported that P supply and cycling rate act as fundamental control on nitrogen fixation, carbon and sulfur dynamics, and P availability limits overall productivity in many natural ecosystems (Vitousek and Howarth, 1991; Pieri, 1992)

The forms, contents, distributions, transformations, and availability of P in soils vary among soil types and may depend on one or combinations of soil properties. The soil properties that influence soil P pools are discussed by Tiessen *et al.* (1984); Sharpley (1985); O' Halloran *et al.* (1987) and Borggaard *et al.* (1990). Strong correlation between these soil properties and various P pools

were reported. These soil properties include soil pH (Sharpley, 1985; Havlin *et al.*, 1999; Brady and Weil, 2002), clay content and nature of clay minerals (O' Halloran *et al.*, 1987; Sharpley *et al.* 1989; Yu, 1997; Hesse, 1994; Harris *et al.*, 1996; McIntosh *et al.*, 1999; Pandey *et al.*, 2000), soil organic matter (Bloom *et al.*, 1979; Curtin *et al.* 1996; Yan *et al.*, 1996; Sumner, 1997), soil CEC (Tekalign and Haque, 1991; Hesse, 1994). Amorphous and crystalline Al and Fe oxides in acidic soils and calcareous compounds in basic soil have close relationships with P pools (Sharpley, 1985; Borggaard *et al.*, 1990). Strong correlation between these soil properties and various P pools does not show direct influence of the properties on the P pools. Correlation analysis may inadequately describe relationships because correlation does not insure that direct-cause-effect relationship exists (Wright, 1921). Direct-cause-effect relationship also cannot be done by straight regression, either simple or multiple, because soil properties are commonly inter-correlated. To predict direct cause-and-effect relationships between soil properties and soil P pools path analysis model is important statistical tool which is also adopted by most agricultural and other biological scientists.

Path analysis model, a statistical technique that partitions correlation into direct and indirect effect, differentiates between correlation and causation (Basta *et al.* 1993). This technique uses multiple linear regressions and generates standardized partial regression coefficients (path coefficients/direct effects). It has been employed in soil studies to investigate the cause and effect of soil properties on heavy metal adsorption (Li, 1975; Krishnasamy and Mathan, 2001) and soil properties and P retention of acid soils (Ige *et al.*, 2007). However, its application to P pool in relation to soil properties was not carried out for Nitisols. Path analysis also allows direct comparison of casual relationships between selected soil properties and different P fractions in soil. Therefore, the objective of this study was to investigate the direct and indirect effects of some selected soil properties on different soil P- pools of Nitisols of Wolayta, Ethiopia.

MATERIALS AND METHODS

Soil Sampling

Twelve (12) surface (0-15 cm) samples were collected in 2003 from three long-term cropping systems of five randomly selected farmers' field from Sodo Zuria and Humbo districts, Wolayta zone, Southern Ethiopia. The soils have been classified as Nitisols (FAO, 1998). The cropping systems were enset, grazing lands and maize monoculture. The three cropping systems of the same farmer were adjacent to each other. Soil samples were air dried, crushed with mortar, and passed through 2- mm pore size sieve and used for soil properties and soil P pools analyses and subsequently adjusted to oven dry weight.

Soil pH was measured using a glass combination pH meter in the supernatant of 1: 2.5 soil to solution ratio of H₂O. Soil organic carbon was determined by the wet oxidation method as described by Walkley and Black (1934). Cation exchange capacity (CEC) of the soil was determined from 1 M ammonium acetate saturated samples. Exchangeable K and Na were determined by flame photometer, whereas exchangeable Ca and Mg were determined by atomic absorption spectrophotometer from 1 M ammonium acetate extract. Free Fe and Al were determined by calorimetry from Dithionite-Citrate Bicarbonate (DCB) extracts. Fractionation of inorganic P was performed by successive extraction procedure as described by Chang and Jackson (1957). Available P content was measured after Olsen (Olsen *et al.*, 1954), whereas total phosphorus was extracted by per chloric acid digestion (Olsen and Sommers, 1982). All forms of P in the extracts were determined by calorimetry using molybdate ascorbic acid, as described by Murphy and Riley (1962). Organic P was estimated by subtracting total inorganic P total P. Results are depicted in Table 1

Table 1. Range of physicochemical properties of the soils used in the study

Soil properties	Minimum	maxmium	mean
pH	5.55	7.28	6.38
Sand %	20	50	42
Silt %	14	40	28
Clay %	28	52	42
OC %	2.4	6.75	4.34
CEC cmol kg ⁻¹	6.64	24.54	14,12
Ald %	0.04	1.3	0.33
Fed %	2.52	6.8	4.06
Soil P Pools			
Pt mg kg ⁻¹	160	960	578
Po mg kg ⁻¹	96	671	325
P Olsen mg kg ⁻¹	0	123.9	41.7
Sal-P mg kg ⁻¹	0	30.8	6.91
Al-P mg kg ⁻¹	1.4	100.2	41.9
Fe-P mg kg ⁻¹	13.23	195.3	85.4
Ca-P mg kg ⁻¹	2.7	108	73.6
Red-P mg kg ⁻¹	0.8	88	32.6
Occ-P mg kg ⁻¹	0.45	34.5	22.1

Path and multiple regression analysis

Path analysis was used to evaluate and estimate cause-effect model of soil properties on soil P pools. In path analysis, simple correlation coefficient between dependent variables (P pools) and independent variables (soil properties) were partitioned into direct and indirect effects. Direct effects are termed path coefficients and are standardized partial regression coefficients. Path analysis direct and indirect effects are derived from multiple linear regressions of soil properties on soil P pools and simple correlation values between soil properties. A path analysis model was constructed to examine the relationship between values of soil properties (pH, Clay, OC, and Fed) and values of soil P pools. An idealized input and output path diagram is outlined to show the path model in Fig. 1 and 2.

Backward regression (multiple regression procedure) and Pearson’s correlation analysis were conducted using SAS statistical package (SAS, 2000) with P pools (Pt, Po, Available P, and Pi fractions) as dependent variables and soil properties (pH, sand, silt, clay, OC, CEC, Fed, Ald) as independent variables to test collinearity among the independent variables. Thus, soil properties that did not make significant contributions to P pools determination and to the fit of regression model were step wisely eliminated from the regression equation. Following backward regression analysis, only four soil properties (pH, clay, OC, and Fed) that significantly contribute to the fit of the regression model of most sets of P pools were selected for path coefficient analysis. The fitness of the prediction model was measured by the coefficient of determination (R^2) of the regression model. Only potential tables that fit the model significantly are discussed.

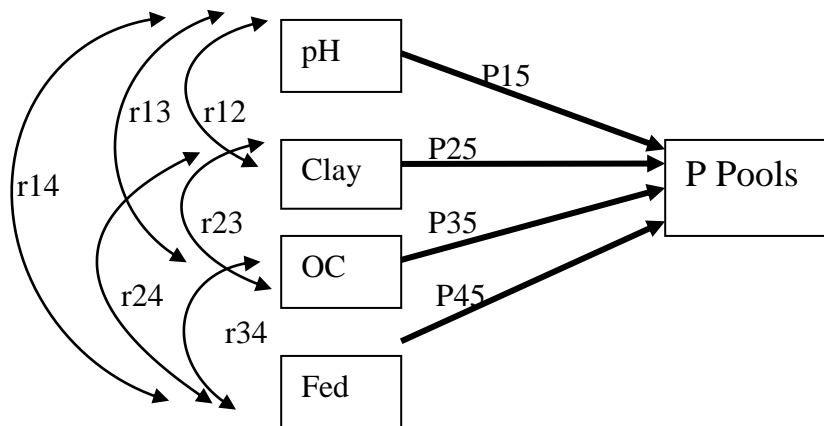

Fig. 1. Path diagram used to determine the effect of soil properties on soil P pools

Where r_{ij} denotes the simple correlation coefficient between soil properties; P_{ij} denotes the path coefficient (direct effects); OC is soil organic carbon; Fed is Dithionite-Citrate-Bicarbonat (DCB) extractable Fe; P pools are total P, organic P, Olsen available P, and inorganic P fractions.

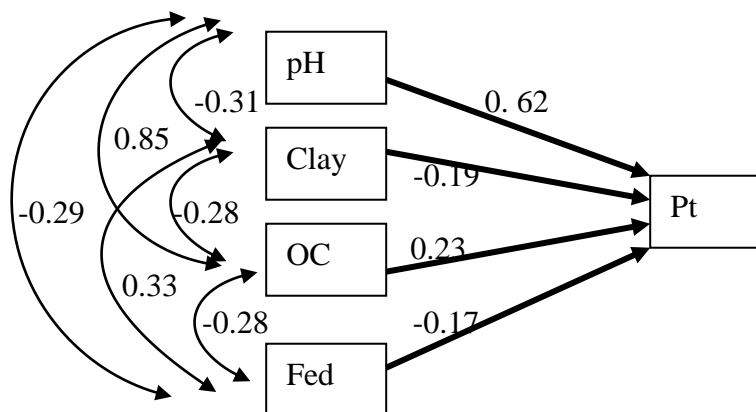

Fig. 2: Path diagram illustrating the relationship among soil properties, and effect of soil properties on total P pool

Direct effects (path coefficients) of soil properties on soil P pools are represented by single-headed arrows whereas intercorrelations between soil properties are represented by two-headed arrows. Correlated causes of soil P and an uncorrelated residual factor (U) were determined in this model. Multiple linear regressions were used to calculate the path coefficients, simple correlation coefficients and uncorrelated residuals (SAS, 2000). The uncorrelated residual of the regressions (U) was calculated from

$$U = \sqrt{1 - R^2} \tag{1}$$

where (R^2) is the coefficient of determination. The correlation between P pools (independent variable y) and soil properties (dependent variable x) is the sum of entire path connecting the two variables and can be calculated as:

$$r_{15} = P_{15} + r_{12}P_{25} + r_{13}P_{35} + r_{14}P_{45} \tag{2}$$

$$r_{25} = r_{12}P_{15} + P_{27} + r_{23}P_{35} + r_{24}P_{45} \tag{3}$$

$$r_{35} = r_{13}P_{15} + r_{23}P_{25} + P_{35} + r_{24}P_{45} \tag{4}$$

$$r_{45} = r_{14}P_{15} + r_{24}P_{25} + r_{34}P_{35} + P_{45} \tag{5}$$

where r_{ij} represents, the simple correlation coefficient between soil properties and soil P pool, P_{ij} are path coefficients (direct effects) of soil properties on soil P concentrations and $r_{ij}P_{ij}$ are the indirect effects of soil properties on soil P pools. Subscript designations are: (1) pH, (2) clay, (3) OC, (4), Fed and (5) soil P pools (Fig. 1).

RESULTS AND DISCUSSION

The correlation matrix between soil properties and soil P pools are presented in Table 2. Significant relationships were observed between most of soil properties and soil P pools. Highly significant ($p < 0.01$) correlations were observed between Pt, and soil pH and OC; Po and pH, OC and CEC; Olsen P, and pH and OC; saloid P and sand content. Significant relationship ($(p < 0.05)$) between saloid P and pH; Al-P, Fe-P and Ca-P, and clay content were also observed. Correlation analysis also showed that significant relationship among soil properties. For instance significant relationship between pH, and OC and CEC; clay and silt; silt and Ald; and sand and Ald.

Table 2: Correlation matrix between soil properties and soil P pools

	pH	C	Si	S	OC	CEC	Fed	Ald	Pt	Po	Ols-P	Sal-P	Ca-P	Fe-P	Al-P
pH	1														
C	-0.31	1													
Si	-0.06	0.74*	1												
S	0.56	-0.55	-0.15	1											
OC	0.85**	-0.28	0.09	0.41	1										
CEC	0.80**	-0.15	-0.07	0.28	0.83**	1									
Fed	-0.29	0.33	0.02	-0.52	-0.28	-0.05	1								
Ald	0.09	-0.34	-0.62*	0.76**	-0.41	-0.29	0.26	1							
Pt	0.88**	-0.51	0.17	0.56	0.86**	0.77*	-0.48	-0.15	1						
Po	0.81**	-0.25	-0.02	0.37	0.87**	0.88**	-0.34	-0.22	0.87**	1					
Ols-P	0.73**	-0.43	0.18	0.18	0.77**	0.60	-0.66	0.18	0.91**	0.82	1				
Sal-P	0.66*	-0.41	-0.18	0.89**	0.44	0.25	-0.43	0.02	0.64	0.42	0.52	1			
Al-P	0.49	-0.76*	0.51	0.55	0.540	0.21	-0.33	0.05	0.59	0.24	0.53	0.49	1		
Fe-P	0.54	-0.67*	0.28	0.66	0.23	0.28	-0.55	-0.04	0.62	0.30	0.59	0.59	0.57	1	
Ca-p	0.31	-0.72*	0.60	0.35	0.26	0.32	-0.10	0.02	0.51	0.21	0.24	0.30	0.55	0.59	1

C = %clay, Si = % silt, S = % sand, OC = organic carbon, CEC = Cation exchange capacity, Fed and Ald = citrate-dithionite-bicarbonate extractable Fe and Al, Pt = total phosphorus, Po = organic phosphorus, Ols-P = olsen P (available P), Sal-P Saloid (easily available P), Ca- P = calcium bound phosphorus, Fe-P = Iron bound phosphorus and Al-P = aluminum bound phosphorus

The path and regression analyses results for the soils are depicted in Table 3. Seven potential tables are presented as single table in concise format consisting of a matrix of direct effects (italics main diagonals) and indirect effects (off diagonals). Very high significant values of coefficient of determination (R^2) and low values of uncorrelated residual (U) values indicate the path analysis model explains most of the variations in soil Pt, Po, Olsen-P, Saloid-P, Ca-P, Al-P and Fe-P pools. However, lower R^2 and higher U values suggested that variations in reductant-P and occluded-P are governed by factors other than pH, Clay, OC, and Fed (data not presented); eliminated from path coefficient matrix table because the.

Both direct effects and r-values indicated strong soil pH influence on Pt, saloid P, and Fe-P (Table 3). Soil pH had significantly high and positive direct effect ($D = 0.618^*$) on Pt, ($D = 1.044^{***}$) on saloid P, and ($D = 1.109^{***}$) on Fe-P. Path analysis also showed that pH had modest and negative indirect effect ($D = -0.478$ and -0.405) on saloid P and Fe-P, respectively, through OC. These results suggest that soil pH is the predominant soil property affecting P availability, its forms and distribution. The higher pH indirect negative effect on saloid and Fe-P may be due to the complexation effect of organic anion and stabilizing in soil solution.

The significant positive correlation between pH and Po observed in the correlation analysis was due to relatively higher indirect effect ($D = 0.473$) of pH through OC indicating the influence of pH on soil organic matter decomposition and direct contribution of soil organic matter to Po pools through mineralization of organic matter. Decomposition of organic matter, solubility of organic compounds and mineralization of organic P are generally stimulated by higher pH (Dalal, 1977). Tisdale *et al.* (1993) also found that microbial activity is much more dependent on soil pH, and hence P mineralization and availability would be affected by soil pH. Although the direct effect of pH on available P was not significant, it was higher than the indirect effects through other variables. Ron vaz *et al.*, (1993) reported that concentration of dissolved reactive phosphate in soil solution of acid soils increased with increased soil pH. Increased pH in acid soils favors P desorption by changing surface charge characteristics (electrostatic potential) of metal oxides surface or by increasing the concentration of ions that increase P solubility (Barrow, 1999)..

Table 3: Path analysis direct (diagonals, underlined) and indirect effects of soil pH, Clay content, soil organic carbon (OC) and Dithionate-Citrate-Bicarbonate extractable (DCB) Fe (Fed) on soil P pools.

		pH	clay	OC	Fed	r	R ²	U
Pt	pH	<u>0.618**</u>	0.061	0.200	0.050	0.928***	0.959***	0.203
	Clay	-0.193	<u>-0.194</u>	-0.067	-0.057	-0.511		
	OC	0.525	0.055	<u>0.235</u>	0.049	0.864**		
	Fed	-0.177	-0.064	-0.006	<u>-0.173</u>	-0.480		
Po	pH	<u>0.370</u>	-0.016	0.473	0.022	0.850**	817*	0.428
	Clay	-0.166	<u>0.050</u>	-0.158	-0.026	-0.249		
	OC	0.315	-0.014	<u>0.556</u>	0.022	0.879***		
	Fed	-0.106	0.017	-0.157	<u>-0.078</u>	-0.325		
Avail- P	pH	<u>0.537</u>	0.024	0.142	0.124	0.827**	0.889**	0.333
	Clay	-0.168	<u>-0.078</u>	-0.047	-0.141	-0.434		
	OC	0.457	0.022	<u>0.167</u>	0.121	0.767*		
	Fed	-0.154	-0.055	-0.047	<u>-0.430*</u>	-0.657*		
Sal-P	pH	<u>1.044***</u>	0.053	-0.478	0.068	0.687*	0.64*	0.600
	Clay	-0.327	<u>-0.168</u>	0.160	-0.077	-0.412		
	OC	0.887*	0.048	<u>-0.563</u>	0.067	0.439		
	Fed	-0.300	-0.055	0.159	<u>-0.236</u>	-0.432		
Al-P	pH	<u>-0.061</u>	0.208	0.341	0.005	0.492	0.700*	0.548
	Clay	0.019	<u>-0.664*</u>	-0.114	-0.005	-0.764*		
	OC	-0.052	0.189	<u>0.401</u>	0.005	0.542		
	Fed	0.018	-0.217	-0.113	<u>-0.016</u>	-0.329		
Fe-P	pH	<u>1.109***</u>	0.135	-0.405	-0.018	0.820**	0.889**	0.333
	Clay	-0.347	<u>-0.431*</u>	0.135	0.021	-0.622*		
	OC	0.942*	0.122	<u>-0.477</u>	-0.018	0.570		
	Fed	-0.318	-0.141	0.134	<u>0.064</u>	-0.261		
Ca-P	pH	<u>0.166</u>	0.234	-0.043	-0.050	0.304	0.554	0.668
	Clay	-0.052	<u>-0.741*</u>	0.014	0.058	-0.720*		
	OC	0.141.	0.210	<u>-0.051</u>	-0.050	0.256		
	Fed	-0.047	-0.242	0.014	<u>0.179</u>	-0.096		

The direct effect of clay on Ca-P, Al-P and Fe-P (readily available P forms) was significant and negative. Its indirect effect is relatively higher on Fe-P through pH, but low and negligible on other P pools through the predictor variables. The path and the correlation analysis results showed that soil clay is the dominant property that influences Ca-P, Fe-P and Al-P pools in Nitisols of the study area. The result is in agreement with the reports of several workers. Soil texture particularly the content and type of clay generally governs nutrient reaction (McIntosh *et al.*, 1999). In modeling soil and plant P dynamics in calcareous and highly weathered soils, Sharpley *et al.* (1989) found that for highly weathered soils clay content explained the greatest amount of variation in sorbed or fertilized P availability index. Phosphorus tends to accumulate in the finer fractions of soil and thus increases as the clay content increases (Hesse, 1994).

Relatively higher positive direct effect of OC was observed on Pt ($D = 0.525$), Po ($D = 0.556$) and Al-P (0.401) through pH as compared to its indirect effects. Its direct effect on Po and Al-P is attributed, in part, to direct contribution of organic matter to Po pools and subsequent transformation of Po to Al-P. Organic C had significantly high indirect effects on Fe-P ($d = 0.942^*$) and saloid P ($D = 0.887$) but due to its modest negative direct effect, the correlation between OC and these P pools was not significant. The indirect effect of OC through pH is attributed in part, to the pH buffering capacity of soil organic matter and in part to competition of organic anions with phosphate anions for sorption sites on the surface of oxides. These results are in line with Barrow (1999) who found that phosphate sorption decreased gently with increase in pH and, Curtin *et al.* (1996); Yan *et al.* (1996); Sumner (1997) and Nelson and Oades (1998) who reported the high pH buffering effect of organic matter on varieties of soils. Organic anions compete with orthophosphate for similar sites on the surfaces of oxides (Sibanda and Young, 1986; Bloom *et al.*, 1979; Robbins *et al.*, 1999) and soils (Frossard *et al.*, 1986; Hue, 1991). The addition of organic matter can increase or decrease soil pH based on the chemical nature of the soil (Yan *et al.*, 1996; Sumner, 1997). The indirect effect of OC on Ca-P is greater than its direct effect through clay.

Fed had significant and negative direct effect ($D = -0.430^*$) on Olsen available P with low negative indirect effect ($D = -0.154$) through pH results in significant and negative correlation ($r = -0.657^*$). Its direct effect is also negative but not significant on saloid P with more negative indirect effect through pH and smaller positive indirect effect through OC. Negative direct effect of Fed on both easily available saloid P and readily available Olsen P suggested that crystalline Fe fix plant available P fractions of P in soil of the study area. Sharpley (1985) and Borggaard *et al.* (1990) also have reported that minerals high in free and amorphous Fe and Al contents are well known sorbents of P and affect extractable P in soils. Small but positive direct effect of Fed was observed on Ca-P which may suggest the transformation of Fe-P to Ca-P in soils. Ryan *et al.* (1985) also reported the importance of iron oxides in modifying the chemistry of P sorption even in calcareous soils.

CONCLUSIONS

This study results have shown that path analysis is more important technique than simple correlation analysis to study the effects of soil properties on different P pools. Direct effects of soil properties on soil P pools were in the order: pH > Clay > OC > Fed for the Wolayta Nitisols. Both correlation and path analysis showed that pH was the dominant soil property affecting directly Fe-P, Saloid-P, and Pt whereas clay influenced most of extractable readily Available P pools. The path model explained 55.4 to 95.9% variations in p pools by predictor variables. Some eliminated variables predicted better than the selected once (for instance silt content significantly predicted Ca-P), however, the same set of variables were used for the model. Although more research is needed to investigate the effects of active calcium carbonate, amorphous Fe and Al, clay types (clay mineralogy), this result can serve as guide in soil P management.

REFERENCES

- Barrow, N.J. 1999. The four laws of soil chemistry: the Leeper lecture. 1998. *Aust. J. Soil Res.* 37(5): 787-831
- Basta, N.T., D.J. Pantone, and M.A. Tabatabai. 1993. Path analysis of heavy metal adsorption by soil. *Agron. J.* 85 (5):1054-1057
- Bloom, P. R., M. B. McBride and R. W. Weaver. 1979. Aluminum and organic matter in acid soil. *Soil Sci. Soc. Am. J.* 43: 813-815. [CrossRef]
- Borggaard, O. K., S. S. Jorgans, J. P. Moberg, and B. Raben-Lang. 1990. Influences of organic matter on phosphate adsorption by aluminum and iron oxides in sandy soils. *Soil Sci.* 41(3): 443-449.
- Brady, N. C. and R. R. Weil. 2002. The nature and properties of soil. 13th ed. Peason Education Inc., Upper Saddle River, New Jersey, USA.
- Chang, S. C. and M. L. Jackson. 1957. Fractionation of soil phosphorus. *Soil Sci.* 84:133-144
- Curtin, D., C. A. Campbell and D. Messer. 1996. Prediction of titratable acidity and soil sensitivity to pH change. *J. Environ. Qual.* 25(6): 1280-1284.
- Dalal, R. C. 1977. Soil organic phosphorus. *Advances in Agronomy.* 28: 83 - 117
- FAO. 1998. World Reference Base for Soil Resources. World Resource Report 84. FAO – ISRIC - ISSS
- Frossard, E., J. W. B. Stewart and R. J. Arnaud. 1989. Distribution and mobility of phosphorus in grassland and forest soils of Saskatchewan, *Can. J. Soil. Sci.* 69: 401-416.
- Harris, W. G., R.D. Kidder and R. Littell. 1996. Phosphorus retention as related to morphology and taxonomy of sandy coastal plain soil materials. *Soil Sci. Soc. Am. J.* 60: 1513 – 1521
- Havlin, J. L., J. D. Beaton and S. L. Tisdale. 1999. Soil fertility and fertilizers. MacMillian Pub. Co., New York.
- Hedley, M. J., J. M. Mortvedt, N. S. Bolan and J. K. Syres. 1995. Phosphorus fertility management in agro-ecosystems. P. 59 – 92. In: H. Tiessen (Ed). Phosphorus in the global environment, transfer, cycles, and management, J. Wiley and Sons. New York, NY.

- Hesse, P.R. 1994. A textbook of soil chemical analysis. Chemical Pub. Co. Ltd; New York, pp. 556.
- Ige, D. V., O. O. Akinremi and D. N. Flaten. 2007. Direct and Indirect Effects of Soil Properties on Phosphorus Retention Capacity. *Soil Sci. Soc. Am. J.* 71(1): 95 – 100.
- Krishnasamy, R., and K.K. Mathan. 2001. Path coefficient analysis of zinc and boron adsorption in soils. *Commun. Soil Sci. Plant Anal.* 32:465–475.
- Li, C.C. 1975. Path analysis—A premier. Boxwood Press, Pacific Grove, CA
- McIntosh, P.D., R. S Gibson, S. Saggar, G. W. Yeates and P. McGimpsey. 1999. Effects of contrasting farm management on vegetation and biological conditions of moist steep land soils of the south Island high country, New Zealand. *Aust. J. Soil Res.* 37: 847-866.
- Murphy, J. and J. P. Riley. 1962. A modified single solution method for the determination of phosphate in natural waters. *Anal. Chem. Acta.* 27:31-36.
- Nelson, P. N. and J. M. Oades. 1998. Organic matter, sodicity and soil structure. P 67- 91, In: M. E. Sumner and N. Naidu (eds.) sodic soils; distributions, processes, management, and environmental consequences. Oxford University Press, New York, NY.
- O'Halloran,, L. P., J. W. B. Stewart and R. G. Kachanoski. 1987. Influences of texture and management practices on the forms and distribution of soil phosphorus. *Can. J. Soil Sci.* 67: 147 – 163.
- Olsen, S. R. and L. E. Sommers. 1982. Phosphorus. P. 403-429. In: A.L. Page et al. (Ed.). *Methods of soil analysis part 2.* 2Ed. Am. Soc. Agron. Madison. WI
- Olsen, S.R., C.V. Cole, F. S. Wantanab and L. A. Dean. 1954. Estimation of available phosphorus in soils by extracting with sodium bicarbonate. USDA circular 939, US government printing office, Washington, D.C.
- Pandey, S. P., R. S. Singh, and S. K. Mishra. 2000. Availability of Phosphorus and Sulfur in Inceptisols of Central Uttar Pradesh. *J. Indian Soc. Soil Sci.*, 48(1): 118 - 121
- Pieri, C. 1992. Fertility of soils: a future for farming in the West Africa Savanna. Springer, Verlag. Berlin
- Robbins, C. W., D. T. Westermann and I. I. FFreeborn. 1999. Phosphorus forms and extractability from three subsoil's. *Soil Sci. Soc. Am. J.* 65: 1717 – 1724.
- Ron Vaz, M. D., A. C. Edwards, C. A. Shand and M. S. Cresser. 1993. Phosphorus fractions in soil solution. Influencees of soil acidity and fertilizer addition. *Plant and Soil.* 148: 175 – 183.
- Ryan, J. D., D. Curtin and M. A. Chemma. 1985. Significance of iron oxides and calcium carbonate particle size in phosphate sorption by calcareous soils. *Soil Sci. Soc. Am. J.* 49: 74 – 76
- SAS institute. 2000. SAS user's guide. Version 8.2 ed. SAS Inst., Cary, NC.
- Sharpley, A. N. 1985. Phosphorus cycling in unfertilized and fertilized agricultural soils. *Soil.Sci. Soc. Am. J.* 49: 905 – 911.
- Sharpley, A. N., V. Singh, G. Uehara and J. Kimble. 1989. Modeling soil and plant phosphorus dynamics in calcareous and highly weathered soils. *Soil Sci. Soc. Am. J.* 53: 119 – 226.
- Sibanda, H. M. and S. D. Young. 1986. Competitive adsorption of humus acids and phosphorus on goethite, gibbsite and two tropical soils. *Soil Sci. J.* 37: 197-204.
- Sumner, M. E. 1997. Measurement of soil pH: Problems and solution. *Commun. Soil Sci. Plant Anal.* 25: 859-879
- Tekalign Mamo and J. Haque. 1987. Phosphorus status of some Ethiopian soils, Sorption characteristics. *Plants soils.* 102: 261-266
- Tiessen, H., J. W. B. Stewart and C. V. Cole. 1984. Pathways of phosphorus transformation in soils of differing pedogenesis. *Soil Sci. Soc. Am. J.* 48: 853
- Tisdale, S. L., W.L. Nelson and J. D. Beaton. 1993. *Soil fertility and fertilizer.* Fifth Ed., MacMillan Pub. Co., New York.
- Vitousek, P. M. and R.W. Howarth. 1991. Nitrogen limitation on land and in the sea. How can it occur? *Biogeochemistry* 13: 87 - 115.
- Walkley, A. and I. A. Black. 1934. An examination of Degtjareff method for determination of soil organic and proposal modification of the chromic acid titration method. *Soil Sci.* 37: 29-38
- Wright, S. 1921. Correlation and causation. *J. Agric. Res.* 20:557–585.
- Yan,, F., S. Schubert and K Mengel. 1996. Soil pH increase due to biological decarboxylation organic anions. *Soil Biol. Bioch.* 28: 617 – 628.
- Yu, T. R. 1997. *Chemistry of variable-charge soils.* Oxford University Press, New York, Pp. 520.

